

TOWNSHIP OF RAMARAAPPLICATION FOR RURAL MAIL BOX LOCATION PERMIT**TO BE FILLED OUT BY APPLICANT/OWNER**

NAME: \_\_\_\_\_

PROPERTY ROLL #: \_\_\_\_\_

PROPERTY DESCRIPTION: CONC: \_\_\_\_ LOT: \_\_\_\_ PLAN: \_\_\_\_\_ LOT: \_\_\_\_

MUNICIPAL ADDRESS: \_\_\_\_\_

TELEPHONE #: \_\_\_\_\_

E-MAIL ADDRESS: \_\_\_\_\_

Location will be staked on: \_\_\_\_\_

(Date)

**NOTE: PRIOR TO INSTALLATION, THE PROPERTY OWNER MUST MARK THE PROPOSED MAIL BOX LOCATION CLEARLY WITH A STAKE AND NOTIFY THE MUNICIPAL WORKS DEPARTMENT WHEN STAKED.**

PRIOR TO ISSUING THE PERMIT, THE STAKED LOCATION WILL BE INSPECTED. THE PROPERTY OWNER AGREES TO COMPLY WITH THE REQUIREMENTS OF THE MUNICIPALITY WITH REGARDS TO THE CONDITIONS OF MAIL BOX PLACEMENT.

It is understood that all works will be constructed, altered, maintained, or operated at the expense of the undersigned. The issuance of a Permit by the Township does not relieve the owner of the responsibility of complying with relevant municipal bylaws. In consideration of any permit issued in respect of this application, we, the applicant/owner for ourselves, our heirs, executors, administrators, successors and assigns, hereby agree to observe, keep and perform and be subject to the regulations and conditions of the said permit and to indemnify and save harmless, the Township of Ramara as represented by the Manager of Municipal Works or his designated, from and against all loss, cost, changes, damages, whatsoever to which may be put or which the Township may suffer or sustain or for which the Township may be liable by reason of anything done or omitted to be done in the construction, maintenance, alteration or operation of the works authorized.

\_\_\_\_\_  
DATED\_\_\_\_\_  
SIGNATURE of PROPERTY OWNER\_\_\_\_\_  
DATE of ISSUE\_\_\_\_\_  
MANAGER of MUNICIPAL WORKS

**CONDITIONS OF RURAL MAIL BOX PLACEMENT**

1. The said rural mail box shall be located on the same side of the road as existing rural mailboxes, in a position where the courier can reach and service it from his/her vehicle without having an impediment to pedestrian or vehicular traffic, and at a location site that the Manager of Municipal Works or his designate may require.
2. The said rural mail box shall be erected, placed, repaired and maintained so that:
  - a) The box is securely attached to a fixed post or cantilever arm or equivalent so that the mail box does not protrude closer to the road than the rounding of the shoulder, and;
  - b) The bottom of the box is at least 1.1 meters (3.5 feet) above the roadway, and;
  - c) The post (standard wooden post with a maximum 150 mm. diameter or a 50 mm. diameter hollow steel pipe or equivalent) are to be erected, placed, repaired and maintained so that the mail box itself is sitting at the prescribed height, and such posts shall be erected at the rounding of the shoulder area so that the opening to the mail box is at the outside edge of the shoulder, and;
  - d) The mailbox does not obstruct, or obscure other mail boxes nearby, or be an impediment, in itself or in its mounting, to affecting ready delivery or collection of mail or the continued maintenance of Township roads.
  - e) A location sketch is shown as Exhibit "A".
  - f) Any designs that vary from a simple post and box configuration will only be permitted if they do not constitute a hazard and have been approved by the Manager of Municipal Works. Under no circumstance will masonry structures be permitted.
3. The box holder or owner is responsible to keep the mail box level and clear of snow and other obstructions at all times.
4. The box holder/owner is responsible for all maintenance and repair, and all mail boxes and supports must be kept in good repair and properly erected at all times so as to help minimize the possibility of becoming a traffic hazard by the nature of its design and construction.
5. The Township employee(s), contractor(s), agent(s), owned equipment, rented equipment, leased equipment shall not be responsible for the replacement, maintenance, repair or otherwise to the said mail box and supports as a result of snow removal, maintenance or construction operations by the owner.
6. A rural mail box placed, or caused to be placed on a Township Road Allowance is deemed to be a privilege and not a right.

7. This permit, issued by the Township of Ramara under the provisions of Bylaw No. 2005.68 does not relieve the holder of that permit of the responsibility of procuring the permits or licences required by other authorities under other Acts, Regulations, etc. If during the life of the Permit any Bylaw or Regulations are adopted which affect the privileges herein granted, the said Bylaws or Regulations shall be applicable to this permit from the date on which they came into force.
8. This Permit may be cancelled at any time by the Township for breach of the regulations or conditions of the Permit or for such reasons as the Township in its discretion deems proper.

**EXHIBIT “A” TO CONDITIONS OF RURAL MAIL BOX PLACEMENT**

Postal Standards for Rural Mailboxes  
PREFERRED METHOD

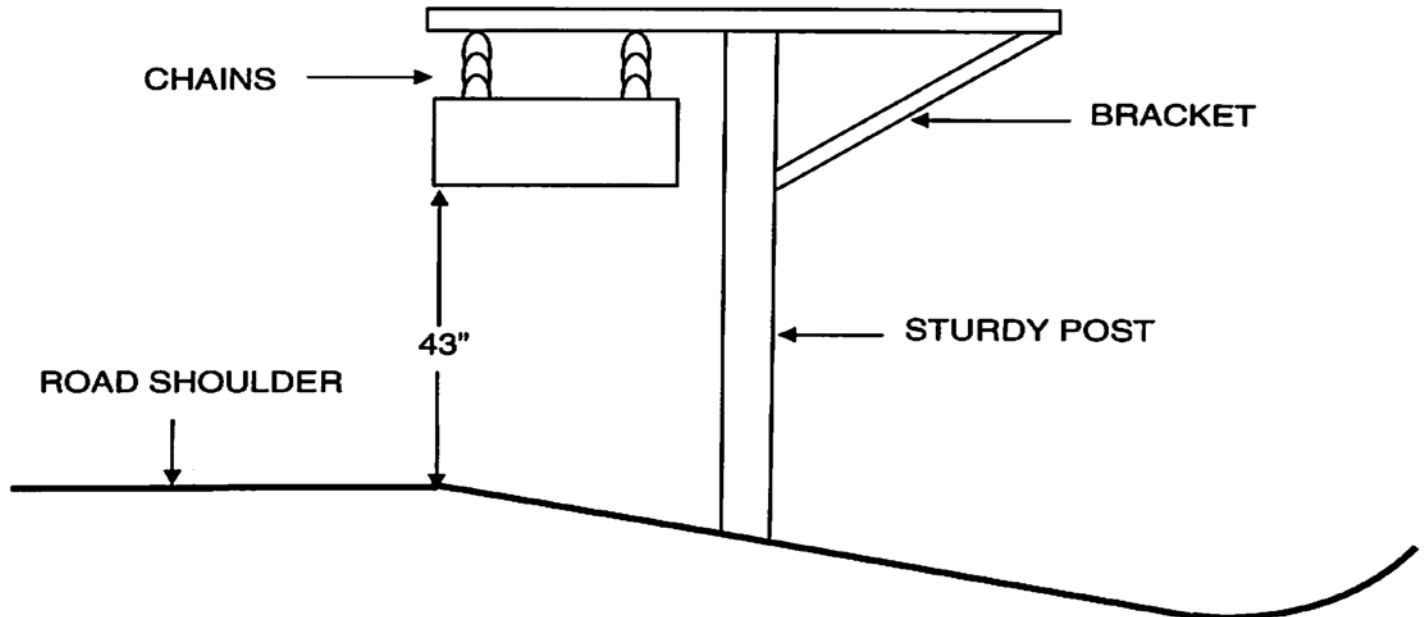

**SCHEDULE “C” TO BYLAW 2005.68**

**SHORT FORM WORDING AND SET FINES**

Item #	Short Form Wording	Set Fine
1.	Erect a rural mail box without a permit	\$105.00
2.	Failure to maintain a rural mail box	\$105.00